

# Dinder 40 Inset Stove V3

## Installation and Operating Instructions

### IMPORTANT

Please attach the stove serial number label in the space provided before placing this manual inside the appliance.

### Serial Number Label Location

---

---

### Installer Information

Upon completion of the installation, these instructions must be handed to the appliance owner or user.

The installer must ensure that the appliance is left in a safe and operational condition and that the user is instructed in the correct operation of the stove, including the use of all controls and safety features.

### Important Notice

**This appliance must be installed by a suitably qualified and competent installer and in accordance with all local building regulations and applicable standards.**

---

## PLEASE READ THESE INSTRUCTIONS CAREFULLY

For your safety and to ensure optimum performance, this appliance must be installed, commissioned and operated in accordance with these instructions.

Failure to follow the installation and operating requirements may invalidate the warranty and could create a safety hazard.

Mendip Stoves cannot accept responsibility for faults, damage, injury or consequential losses arising from incorrect installation, misuse, inadequate maintenance or failure to follow these instructions.

This version reads more like a modern CE/UKCA stove manual and provides clearer legal protection for the manufacturer.

# TABLE OF CONTENTS

Section	Page
<b>1. List of Components</b>	2
<b>2. Component Identification and Assembly</b>	2
<b>3. Stove Commissioning Checklist</b>	4
<b>4. Installation Instructions</b>	5
4.1 Warnings and Important Safety Information	
<b>5. Installation Information</b>	7
5.1 Warnings and Important Safety Information	
5.2 Health and Safety Precautions	
5.3 Site Requirements	
5.4 Stove Installation	
<b>6. Technical Data</b>	12
<b>7. Operating Instructions</b>	13
7.1 Air Controls	
7.2 Cleaning	
7.3 Recommended Fuels	
7.4 Notes on Wood Burning	
7.5 Lighting the Stove	
7.6 Refuelling	
7.7 Shutting Down	
7.8 Maintenance	
7.9 Seasonal Use	
<b>8. Safety Notes and Guidance</b>	18
<b>9. Frequently Asked Questions</b>	19
<b>10. Spare Parts List and Part Codes – Dinder 40 (V3)</b>	20

---

**Document:** Dinder 40 Inset Stove V3 – Installation and Operating Instructions

# 1. List of Components

Description of Parts	Qty
Dinder Stove Assembly	1
Stove Tool	1
Door Tool	1
Ash Pan	1
Instruction Manual	1
Lower Baffle	1
Stove Operating Glove	1
Touch up paint	1

Fig 1 – Ashpan Tool & Door Tool

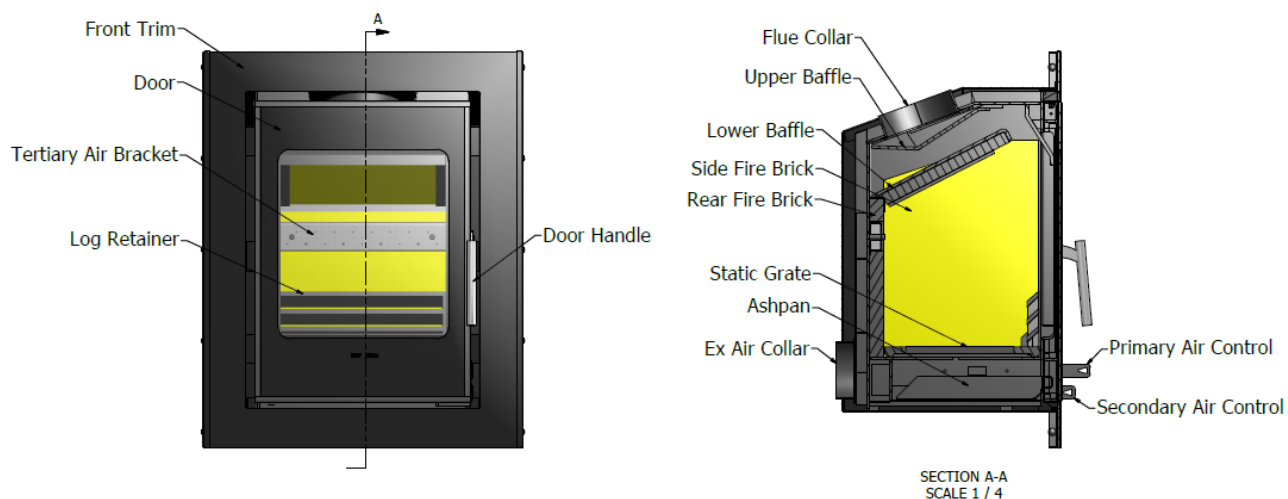
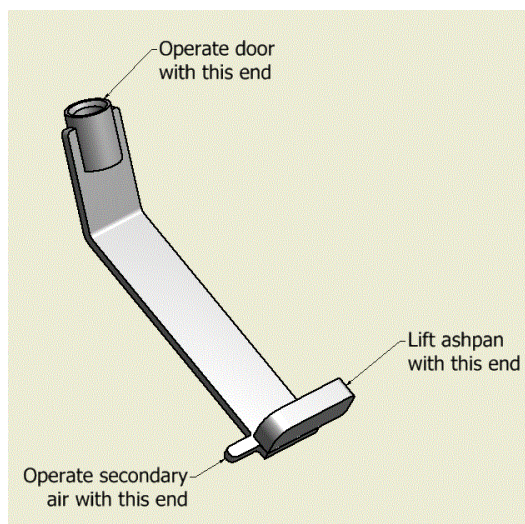

Fig 2 – Stove Assembly and controls

## 2. Component Identification and Assembly

Your Dinder 40 Inset Stove is supplied securely packaged for transportation. Carefully remove all straps, timber supports, cardboard and plastic packaging materials.

Open the stove door and remove all loose components from inside the appliance. Refer to the **List of Components** section and check that all items are present and undamaged before proceeding with the installation.

### 2.1 Removal of Internal Components

To reduce the weight of the appliance during installation, the internal components should be removed as follows:

1. Carefully lift the front edge of the baffle plate and slide it forward until it clears the retaining pegs.
2. Lower the baffle plate and remove it through the door opening.
3. Remove the two side vermiculite panels followed by the two rear vermiculite panels.

**Important:** Vermiculite panels are fragile. Handle them with care and store them in a safe location where they cannot be damaged.

### 2.2 Removal of Grate Components

Lift out and remove the riddling grate and grate assembly from the stove.

### 2.3 Stove Installation

The appliance is now ready for installation. Install the stove in accordance with these instructions, all applicable Building Regulations, and current industry best practice, including HETAS guidance where applicable.

Once the stove has been installed, reassemble the internal components by reversing the removal procedure described above. Ensure that all components are correctly positioned before commissioning the appliance.

**Note:** As this is a multifuel inset stove, I have retained the grate and riddling mechanism terminology. If the Dinder 40 is wood-only, the wording should be adjusted to refer to the base plate and ashpan instead.

### **3. Stove Commissioning Checklist**

Please complete the form below as it will be of great assistance in the unlikely event that there is a problem with the stove or a warranty claim needs to be made. Please contact the installer or dealer if there is a problem.

#### **Retailer from whom the appliance was purchased**

Name: .....

Address: .....

.....

Telephone Number: .....

#### **Complete upon stove installation**

Date of Installation: .....

Model Number: Dinder 40.....

Serial Number: .....

#### **Fitter/Plumber**

Name: .....

Address: .....

Telephone Number: .....

#### **Commissioning Checklist – Installer to complete and sign off**

Stove is correctly flued according to building regulations

Flue swept and integrity of flue verified

Smoke test completed on the installed stove

Spillage test completed

Use of the appliance and operation of controls are explained to the end-user

Check that the specified clearance to combustibles has been adhered to

Instruction manual handed to end-user / Notice plate completed and fixed into position.

Installer Signature: .....Installer Name (print): .....

# 3. Installation Instructions

## IMPORTANT – READ THESE INSTRUCTIONS CAREFULLY BEFORE INSTALLATION

Before commencing installation, it is essential that the installer fully understands the requirements of the relevant National Building Regulations and applicable standards.

Installation must comply with:

- Building Regulations Approved Document J (England and Wales)
- Building Standards Technical Handbook – Section 3 (Scotland)
- Technical Guidance Document J (Republic of Ireland)
- All relevant British and European Standards, including BS 8303, BS 6461, BS EN 15287-1 and BS 7566
- Any local authority requirements or regulations

In the event of any conflict between these instructions and statutory regulations, the statutory regulations shall take precedence.

### 3.1 Health and Safety Precautions

All work must be carried out in accordance with the requirements of the Health and Safety at Work Act 1974 and all relevant regulations, codes of practice and guidance applicable at the time of installation.

#### Handling

Appropriate equipment and assistance must be available for unloading and positioning the appliance. The Dinder 40 Inset Stove is a substantial cast-iron and steel appliance. Always use safe lifting techniques and seek assistance when moving or installing the stove.

#### Fire Cement

Some types of fire cement are caustic and may cause skin irritation. Avoid direct contact with the skin and eyes. In the event of contact, wash immediately with plenty of clean water and seek medical advice if irritation persists.

#### Asbestos

This appliance contains no asbestos. If there is any possibility of disturbing asbestos-containing materials during installation, specialist advice must be sought and appropriate protective measures must be taken before work proceeds.

#### Metal Parts

The appliance contains metal components and edges that may be sharp.

Suitable protective gloves should be worn during installation and servicing to reduce the risk of injury.

## **Chimney Warning**

**This appliance must not be connected to a chimney or flue system serving any other appliance.**

The chimney or flue system must be dedicated solely to this appliance and must comply with all relevant regulations and standards.

## **Extractor Fan Warning**

**An extractor fan must not be installed in the same room as the appliance unless appropriate tests have been carried out to demonstrate safe operation.**

Extractor fans can create negative pressure within the room, potentially causing combustion gases or fumes to be drawn into the living space.

Refer to the current Building Regulations Approved Document J for further guidance.

## **Cleaning and Chimney Sweeping**

The appliance, flue pipe and chimney system must be inspected and cleaned regularly.

Particular attention should be paid following periods of non-use, such as after the summer season.

- Regularly remove and inspect the baffle plate for soot or debris accumulation.
- Check that the flue outlet and connecting flue pipe remain free from obstruction.
- Inspect the chimney and flue system at regular intervals during use.
- The chimney and connecting flue pipe must be swept at least once per year and more frequently when burning solid fuels that produce higher levels of soot deposits or when using inadequately seasoned wood.

Any damaged, loose or leaking components within the flue system must be repaired immediately before further use of the appliance.

## **Fuels**

Only fuels recommended within this manual may be used.

Burning unsuitable materials may damage the appliance and create a serious safety hazard.

The following must not be burned:

- Petroleum coke
- Liquid fuels
- Household waste
- Treated timber
- Plastics
- General rubbish or waste materials

**This appliance must not be used as an incinerator.**

The use of unauthorised fuels may invalidate the appliance warranty and compromise safe operation.

## Maintenance

To ensure the continued safe and efficient operation of the appliance, the stove, flue system and chimney should be inspected and serviced at least once every year by a suitably qualified engineer.

Any worn, damaged or defective components should be replaced only with genuine replacement parts recommended by Mendip Stoves.

## Ventilation

Adequate permanent ventilation must be provided in accordance with current Building Regulations.

For appliances installed in rooms with an air permeability greater than  $5.0 \text{ m}^3/(\text{h}\cdot\text{m}^2)$ , a permanent air vent is normally not required for appliances with a rated output of 5kW or less. For appliances above 5kW, additional ventilation of **550mm<sup>2</sup> per kW** of rated output above 5kW must be provided.

For buildings with an air permeability of less than  $5.0 \text{ m}^3/(\text{h}\cdot\text{m}^2)$ , a permanent air supply of **5,500mm<sup>2</sup> per kW** of appliance rated output is required.

**Note:** Where another appliance requiring combustion air is installed in the same room or an adjoining room, additional ventilation may be required.

Refer to the latest edition of Building Regulations Approved Document J for detailed ventilation requirements.

**Important:** An extractor fan must not be fitted in the same room as the appliance, as it may cause combustion gases to be drawn into the room.

# 4. Installation Information

## 4.1 Chimney Requirements

The chimney height and terminal position must comply with the relevant Building Regulations and applicable standards.

The chimney must provide sufficient draught to safely remove the products of combustion and should be:

- Structurally sound
- Dry and free from damp penetration
- Free from cracks, blockages and obstructions
- Swept and inspected before installation

The chimney flue diameter must not be less than **150mm** and should not exceed **200mm** unless otherwise approved for the installation.

If the chimney does not meet these requirements, it must be lined using a suitable lining system approved for solid fuel use.

Where an existing chimney has previously served an open fire, deposits within the flue may become dislodged due to the higher operating temperatures of the stove. It is therefore recommended that the chimney is swept again after approximately one month of regular operation following installation.

If there is any doubt regarding the suitability of the chimney, consult a qualified chimney engineer or HETAS registered installer.

Where no existing chimney is available, a prefabricated system chimney or twin-wall insulated stainless steel flue system certified to BS EN 1856-1 may be used. Such systems must be installed in accordance with the manufacturer's instructions and the requirements of BS EN 15287-1.

## 4.2 Flue Draught

For satisfactory operation, the appliance requires a flue draught between:

- **Minimum:** 12 Pascals (1.2mm water gauge)
- **Maximum:** 25 Pascals (2.5mm water gauge)

The draught should be measured with the appliance operating at high output.

Where the flue draught exceeds the recommended maximum, a suitable draught stabiliser should be fitted to prevent over-firing and excessive fuel consumption.

## 4.3 Connection to the Chimney

This appliance is not suitable for connection to a shared flue system.

A direct connection must be made between the appliance flue spigot and the chimney or flue liner.

Where practical, an existing fireplace opening may be sealed using a suitable register plate, allowing a connecting flue pipe of not less than **150mm internal diameter** to be installed between the appliance and the chimney system.

The connecting flue pipe must comply with all relevant Building Regulations and applicable standards.

The appliance should be securely installed within the fireplace opening and insulated using a **6:1 vermiculite-to-cement insulating mix**, incorporating only sufficient water to achieve a workable consistency.

The visible finishing surface may be completed using a **1:1:8 mix of cement, lime and sand**.

The flue spigot is fitted by inserting it from inside the appliance and rotating it into the keyhole fixing slots provided.

Ensure that the connecting flue pipe is positioned no closer than **76mm** to the rear or side chimney walls.

Where necessary, access into the chimney above the fireplace opening should be created to enable correct connection of the appliance to the flue system.

If there is any uncertainty regarding installation methods, consult the latest HETAS installation guidance.

**Important:** All joints between the appliance, connecting flue pipe and chimney system must be sealed and made airtight using suitable fire rope, clamping bands, fire cement or high-temperature sealing compounds as appropriate.

Both the chimney and flue pipe must be accessible for cleaning and if ANY parts of the chimney cannot be reached through the stove (with baffle removed), a soot door must be fitted in a suitable position to enable this to be done.

In adverse weather conditions, downdrafts may occur causing smoke or fumes to spill into the room. If this occurs the appliance should be shut down as much as possible by closing the air controls and the room should be ventilated to clear the fumes. If the problem persists seek the advice of a chimney sweep.

## Material Clearances

### Safety Distances from Combustible Surfaces:

Model	Back	Side	Floor
Dinder 40	200mm	200mm	500mm

This appliance must be installed in a recess which must not contain any combustible materials. Wooden battens and plasterboard should not be used within the clearance to combustibles.

In addition it is strongly recommended that any furniture or other combustible materials are kept at least **1300mm** clear from the front of the stove and any mantle is at least **700mm** above the stove.

### Hearths:

This stove require a 125mm thick non-combustible constructional hearth beneath them to protect the building, this can include any solid non-combustible floor. A non-combustible superimposed hearth forming an apron of at least 225mm at the front of the stove and 150mm on either side must also be provided. The superimposed hearth must not be less than 12mm thick and must have a clearly defined edge (change of level) to discourage placing of any combustible materials on or partially over it.

The appliance must be installed on a floor with adequate load-bearing capacity. If the existing construction does not meet this requirement, suitable measures (e.g. load distributing plate) should be provided to achieve it.

## 4.4 Fitting the stove

### Installing the Stove

Please note that the each installation is unique to the particular household and it is not possible to give recommendations in this manual to cover every situation. The installation must comply with building regulations and be completed using “Best Practice” methods.

**Note that most fireplaces have a supporting Lintel. Never remove this without first supporting the remaining structure of the building. The stove or flue system must not be used to support the structure of the building.**

The fitting of the cassette stove is different depending on whether the chimney is already lined or not. The fitting in both scenarios is described below. Note that it is best practice to line every chimney.

#### **A – Installing a stove into a chimney that needs to be fully lined (see fig. 3)**

- (i) Ensure the fireplace is suitable for the stove. The opening should measure 410-480mm wide x 550-580mm high and a minimum of 370mm deep for the Dinder 40
- (ii) Drop the flexi liner down the chimney using fig. 3 as guide. Ensure a flexi stop or plate is used at the bottom of the clay lined/unlined chimney to stop the loose vermiculite from falling down. Note the height of the flue collar of the stove and cut the flexi flue to length accordingly and fit a flexi-adaptor to the flexi liner and seal on the inside between the flexi liner and flexi adaptor with fire cement. It is important this joint is airtight for proper operation of the stove. Leave the flexi liner and adaptor hang down and the opening is now ready for the stove to be fitted.
- (iii) Remove the lower baffle from the stove by lifting the front of the baffle and pull it forward a little which will allow it to drop down and be easily removed from the stove and put to one side. Carefully remove the firebricks and place to one side. Note the fire bricks can be brittle (especially after use) so handle with care. Remove the ash pan. Remove the screw from the bottom of the riddle grate and remove the riddle grate from the stove. Lift the grate to expose the four fixing holes. Also loosen the two screws securing the top baffle and pull the baffle forward until it drops down and remove it. The front door can also be easily removed before lifting into position if desired.
- (iv) Lift the stove into position taking care not to scratch the hearth and push into the opening until the front trim is up against the front of the opening. Drill through the four holes in the base of the appliance into the concrete base under the appliance using a concrete bit., Ref fig 6 for position of outer casing.
- (v) Fill any void at the back or sides of the box with 6:1 vermiculite / cement mix or any other good quality non-combustible insulation material. It is important that the back and sides of the box are well insulated.
- (vi) **Always use a minimum of 600mm of 3mm single wall connecting flue between the stove and the flue where possible, if using flexi flue ensure it is T600 rated and any adaptors are 1mm stainless steel.** the adaptor to the collar of the stove and seal between the collar and the inside using fire cement. It is important this joint is airtight for proper operation of the stove.
- (vii) Replace the door, baffles, liner and grates by completing step (iii) in reverse.

### Commissioning and Handover

Upon completion of the installation, allow a suitable period of time for any fire cement and mortar to dry out. A small fire may then be lit and checked to ensure the smoke and fumes are taken from the stove up the chimney and emitted safely to the atmosphere.

Notice plate should be filled out with indelible ink and located either (A) next to the electricity consumer unit, (B) next to a gas consumer unit or (C) next to the chimney or hearth.

Advise the customer not to run the stove at full output for at 3 – 4 days. Explain that the stoves can provide much more or less than their rated heat outputs depending upon how they are burnt and fuels and fuel loads used.

On completion of the installation and commissioning, ensure that the operating instructions and operating tools (including glove) for the stove are left with the customer. You must be sure to advise the customer on the correct use of the appliance, along with clear and comprehensive information on any continuing maintenance required for the effective operation of the appliance in order to protect the health and safety of the building occupants. Inform them to use only the recommended fuels for the stove.

Advise the user on what to do should smoke or fumes be emitted into the room from the stove – see **Safety Notes** section. The user should be warned that they **MUST** use a suitable fireguard in the presence of children, aged and/or infirm persons.

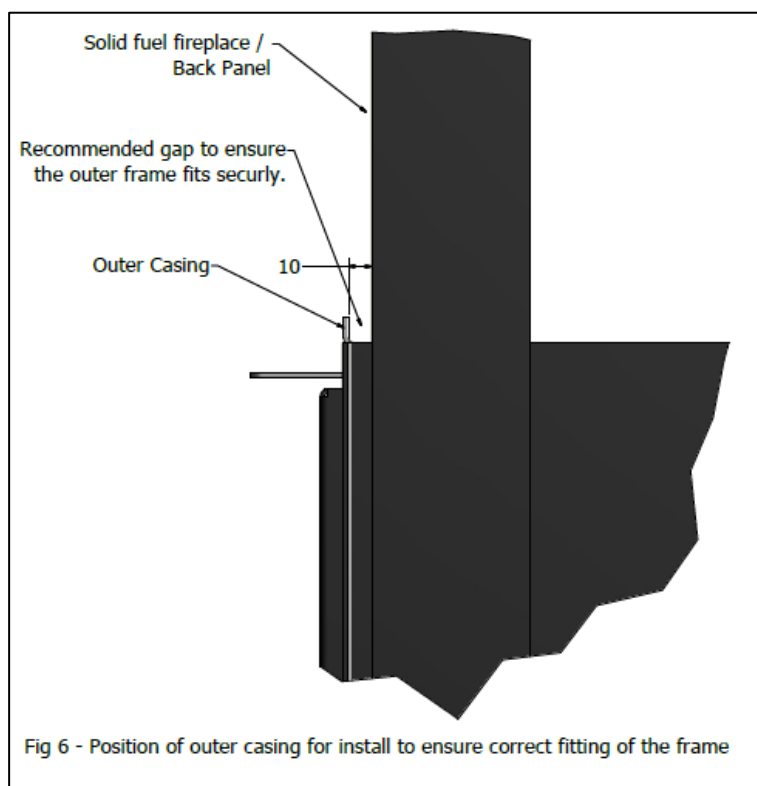
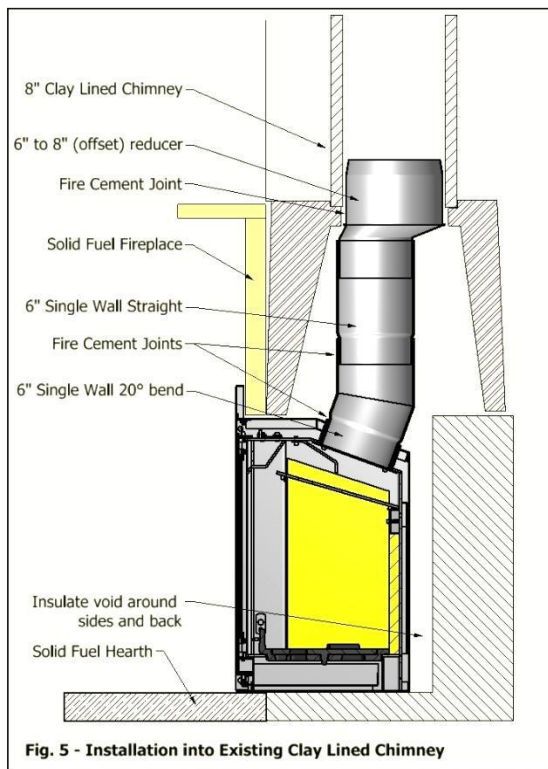
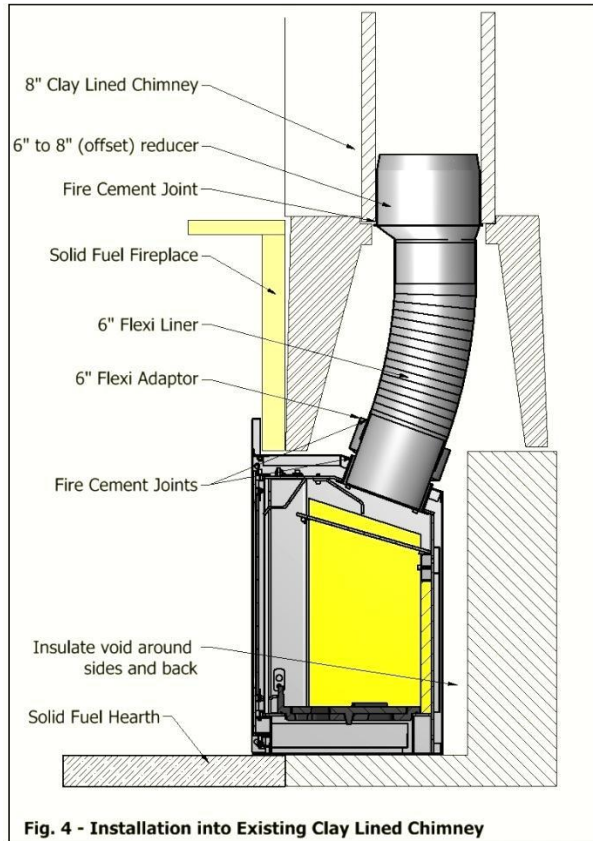
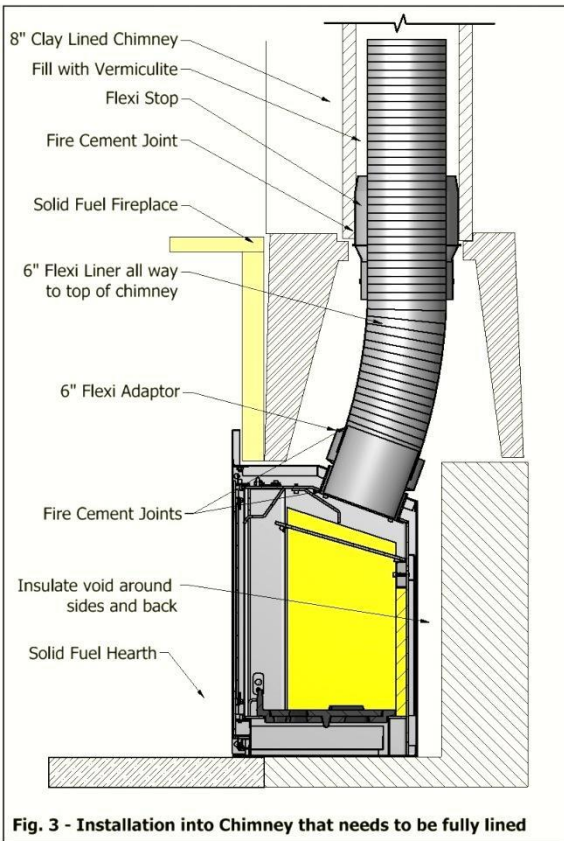

## 5. Technical Data

Technical Specifications		
	<b>Dinder 40</b>	
<b>Fuel</b>	<b>Wood</b>	
<b>Nominal Heat Output (kW)</b>	5	
<b>Efficiency (%)</b>	82.3	
<b>CO@13% O2</b>	0.06	
<b>No<sub>x</sub></b>	103 mg/m <sub>o</sub> <sup>3</sup>	
<b>C<sub>x</sub>H<sub>y</sub></b>	15 mgC/m <sub>o</sub> <sup>3</sup>	
<b>Dust</b>	22 mg/m <sub>o</sub> <sup>3</sup>	
<b>*Flue Temp: (°C)</b>	262	
<b>Flue gas mass flow: (g/s)</b>	3.6	
<b>Flue Outlet Size (Inch)</b>	5	
<b>Fuel Consumption (kg/hr)</b>	1.35	
<b>Max Log Length:</b>	300mm	
	<b>Weight</b> 66.5kg	
<b>Recommended fuels</b>	<b>Wood</b>	Kiln dried / Seasonal wood with moisture content less than 20% / Compressed hardwood logs

\*Average reading at nominal output

## Dinder 40 Cassette Dimensions

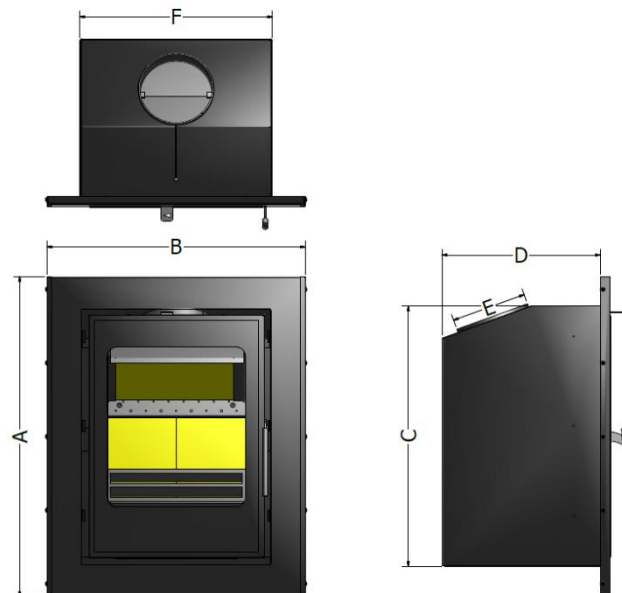

Dimensions in MM	A	B	C	D	E	F
Dinder 40	680	547	553	355	127	408

## 6. Operating Instructions

This appliance is designed to operate with the door closed and must not be operated with the door left open except during lighting, refuelling or servicing.

The Dinder 40 Inset Stove has been engineered to provide clean combustion, high efficiency and excellent flame visuals. When operated correctly and using the recommended fuels, the appliance will provide efficient heat output, reduced emissions and a clear glass viewing window.

For safe and efficient operation, it is essential that the appliance receives an adequate supply of combustion air. The primary, secondary and tertiary air inlets must be kept free from obstruction at all times.

**Warning:** During operation, all external surfaces, controls and fittings may become extremely hot. Care should be taken when operating the appliance.

A protective glove is supplied with the stove and should always be used when adjusting controls, opening the door or handling components during operation.

**Do not use aerosol sprays near the appliance when it is lit or still hot.**

### 6.1 Air Controls

## Primary Air Control

The primary air control is located at the lower right-hand side of the appliance.

Primary air is supplied beneath the fuel bed and is primarily used when lighting the stove or reviving a low fire.

When burning wood, the primary air control should normally be fully closed once the fire is established.

- Sliding the control forwards increases the primary air supply.
- Sliding the control backwards decreases the primary air supply.

## Secondary Air Control (Airwash System)

The Dinder 40 is fitted with an advanced airwash system designed to help maintain a clean glass viewing window.

The secondary air control is located at the lower right-hand side of the appliance and supplies preheated air across the inside surface of the glass.

For optimum glass cleanliness and combustion performance, the secondary air control should normally remain partially open whenever the stove is in operation.

- Moving the control towards the wider end of the indicator increases the air supply and burn rate.
- Moving the control towards the narrower end of the indicator decreases the air supply and burn rate.

Avoid operating the appliance for extended periods with the secondary air fully closed, as this may result in poor combustion and excessive glass blackening.

## Tertiary Air System

The appliance incorporates a preheated tertiary air system designed to improve combustion efficiency and reduce emissions.

This system introduces additional oxygen into the upper region of the firebox, enabling unburnt gases to ignite before leaving the appliance.

During normal operation, particularly at higher temperatures, small jets or ribbons of flame may be visible emerging from the tertiary air outlets located towards the rear of the firebox. This is a normal feature of clean-burn combustion technology.

## Static Grate

The appliance is fitted with a robust static grate designed for use with the fuels recommended in this manual. When burning wood, a shallow bed of ash may be beneficial and can assist combustion performance. However, excessive ash accumulation should be avoided as it reduces the available firebox volume and may adversely affect stove performance.

Ash levels should therefore be monitored and removed regularly.

## Ashpan

The ashpan should be emptied regularly and must not be allowed to become overfilled.

Excessive ash accumulation may interfere with the combustion air supply and reduce appliance performance. To remove the ashpan:

1. Open the stove door carefully.
2. Use the operating tool provided to engage the ashpan handle.
3. Carefully lift the ashpan from the appliance.
4. Empty the contents into a suitable non-combustible container.

**Warning:** Ashes may remain hot for many hours after the fire has gone out. Always use suitable protective equipment and store ashes in a metal container with a secure lid until completely cold.

After emptying, return the ashpan to its correct position and ensure it is fully located within the appliance before further operation.

### 6.2 Cleaning

**Glass:** Despite the advanced air wash system provided, the glass will still need cleaning from time to time depending on the fuel quality and burning rates used. Never clean glass when the stove is hot. Always use stove glass cleaner or ceramic hob cleaner, which is available from your stove retailer. As an alternative, use a wet cloth with some of the wood ash if burning wood but be very careful to use very clean ash so as not to scratch the glass. **See Guidance note on the last page of the manual.**

**Outer body:** The outer body simply needs to be dusted from time to time. DO NOT use any kind of furniture polish or cleaning agent other than your stove suppliers recommended paint.

**Inner firebox:** Brush the inside of the firebox clean from time to time to check the integrity of the plates and liners etc. It is not normally necessary to re-paint inside the firebox due to the high temperatures that mean that the paint does not have much effect before being burnt off. Steel and vermiculite board liners are resilient firebox materials and will give reliable service without major cleaning or work on the firebox. The liner boards may require replacement fairly regularly depending upon fuels and the type of usage experienced. Lining boards are not covered by warranty, as they are a wearing consumable part.

**Baffle:** It is essential to check the top of the baffle for build-up of soot and ash regularly when in use and after a long period of no use. From time to time remove the baffle if necessary to ensure that the flue way entrance is clear.

### 6.3 Fuels

#### **Wood**

Burn only seasoned timber products with a moisture content of less than 20%. To obtain this moisture content allow cut wood to dry for at least 12-18 months. **Do not burn construction timber, treated or painted wood, manufactured board or pallets.**

## **6.4 Notes on Wood burning**

With a full load of wood, the stove will need to be refuelled approximately every 0.75 hours depending on burn rate. Wood can be stacked in the stove but care must be taken that logs do not touch the baffle. Do not stack fuel above the level of the tertiary air inlets at the back of the stove.

Always make sure that flames are visible above the wood after re-fuelling for cleanest burning. Open the air wash full for 1 to 2 minutes to achieve full flames above the fuel. Carefully adjusting the secondary air controls and fuel load will then control the burn rate of the stove. Wood burns most efficiently with the primary air controls closed and the secondary (air wash) controls open about 25%, this setting will give the stoves nominal output.

**See also:** section entitled 'Lighting the Stove'.

Wood burns best on a bed of ash and it is therefore only necessary to remove surplus ash from the stove occasionally. **If the grate is completely clear, place a few handfuls of ash into the slots in the grate to help the firebed build up.**

Burn only dry, well-seasoned wood, which should have been cut, split and stacked - under protection from rain - for at least 12-24 months with free air movement around the sides of the stack to enable it to dry out. Burning wet or unseasoned wood will create tar deposits in the stove and chimney and will not produce a satisfactory heat output. **Wood that is not properly dry ('dry' is considered to be less than 20% internal moisture content) uses up energy from the burn process to evaporate the water inside the wood thus creating very poor conditions for combustion.** The main cause of burning problems with wood stoves is due to excessively damp wood. Wood can appear perfectly dry on the outside but still contain 40-50% water on the inside. A moisture meter can be purchased from some stove and equipment suppliers if you wish to check your wood source is correct.

## **6.5 Lighting the Stove**

### **Initial Curing Fires**

Before operating the appliance at maximum output, it is recommended that two or three small fires are burned to gradually cure the paint finish and allow the appliance components to settle into service. During this process, an odour may be noticed as the high-temperature paint cures fully. This is normal and non-toxic. For comfort, ensure that the room is well ventilated by opening doors and windows during the curing period.

### **Lighting Procedure**

1. Fully open both the primary and secondary air controls.
2. Place suitable firelighters, crumpled paper and dry kindling into the firebox.
3. Light the fire at the base of the fuel bed.
4. Leave the stove door slightly ajar for approximately 10 minutes to assist ignition and establish a strong chimney draught.

**Warning:** Never leave the appliance unattended while the door is left ajar.

5. Once the kindling is burning well, gradually add small pieces of dry wood.
6. Build the fire progressively until a good bed of glowing embers has been established.
7. Add further fuel as required, avoiding excessive loading during the early stages of combustion.

Do not close the air controls prematurely or overload the firebox before the fire has become fully established. Once a stable firebed has formed:

- Fully close the primary air control.
- Gradually reduce the secondary air control to achieve the desired burn rate.

For normal wood-burning operation, the secondary air control will typically remain approximately 25% open, although this may vary depending on fuel quality, chimney draught and heating requirements.

## 6.6 Refuelling

As wood is consumed, the flames will gradually reduce and the remaining fuel will form a bed of glowing embers. The ideal time to refuel is when active flames have diminished and a substantial ember bed remains.

**Note:** If the flames disappear while large pieces of wood remain unburnt, this may indicate:

- Excessive moisture content in the fuel.
- Insufficient combustion air.
- Inadequate chimney draught.

### Refuelling Procedure

1. Open the door slowly to prevent smoke spillage.
2. Add one or two suitably sized logs onto the ember bed.
3. Fully open the secondary air control for approximately 1–2 minutes.

This additional air supply encourages rapid ignition of the new fuel and helps minimise smoke emissions. Once flames are clearly established above the new logs, reduce the secondary air control to the desired operating position.

### Important:

- Do not allow newly loaded logs to smoulder without visible flames.
- Sustained smouldering combustion will increase emissions, reduce efficiency and encourage soot deposits.
- Do not load fuel above the tertiary air inlet holes located at the rear of the firebox.

### Fuel Loading Guidance

- Small logs provide a higher heat output for a shorter period.
- Medium logs provide a balance between heat output and burn duration.
- Large logs generally burn for longer periods with a lower average heat output.

The appliance is approved for intermittent operation and will typically require refueling at intervals of approximately 45 to 90 minutes, depending on fuel type, fuel load and operating conditions. Where the fire has become weak, remove excess ash if necessary and use small pieces of dry wood with increased air supply to re-establish vigorous combustion before adding larger logs.

## 6.7 Shutting Down

Under normal conditions, the appliance will extinguish naturally as the fuel is consumed.

To intentionally shut down the appliance:

1. Close the primary air control (if open).
2. Gradually close the secondary air control.

The fire will progressively burn down and eventually extinguish. If it becomes necessary to revive the fire before it has gone out completely, reopen the secondary air control fully and add suitable dry fuel if required.

**Warning:** The appliance will remain hot for a considerable period after the fire has gone out. Surfaces, controls and internal components may cause burns.

**Warning:** Petroleum coke, liquid fuels, household waste and other unauthorised fuels must not be burned in this appliance.

## 6.8 Maintenance

The firebox, baffle plate and flue outlet should be inspected regularly during the heating season.

At least once each week during periods of regular use:

- Inspect the firebox lining panels.
- Check above the baffle plate for soot or ash accumulation.
- Ensure the tertiary air inlets remain clear.
- Check that all air controls operate correctly.

Refer to Section 3 – Cleaning and Chimney Sweeping for additional maintenance requirements. Only genuine Mendip Stoves replacement parts should be used when servicing or repairing the appliance.

## 6.9 Seasonal Use

Following extended periods of non-use, such as during the summer months, the appliance should be inspected before relighting. The following checks should be carried out:

1. Remove the baffle plate.
2. Inspect the flue outlet and internal flueways.
3. Ensure that the chimney and connecting flue system are completely clear and free from obstruction.
4. Check that all air controls operate freely.

To reduce the possibility of condensation and internal corrosion during periods of non-use, leave the air controls partially open to allow ventilation through the appliance.

Any signs of damage, corrosion or obstruction should be rectified before the appliance is returned to service.

## **7.0 Safety Notes for your guidance**

***FIRES CAN BE DANGEROUS*** – Always use a fireguard in the presence of children, the elderly or the infirm.

**DO NOT OVERFIRE** – it is possible to fire the stove beyond its design capacity, this could damage the stove, so watch for signs of overfiring – if any part of the stove starts to glow red, the fire is in an overfire situation and the controls should be adjusted accordingly. Never leave the stove unattended for long periods without first adjusting the controls to a safe setting – careful air supply control should be exercised at all times. Any unauthorised modifications of this appliance will render the guarantee null and void and could be potentially dangerous. Replacement parts should only be sourced from San Remo approved dealers

### **CO ALARMS**

Building Regulations require that whenever a new or replacement fixed solid fuel or wood/biomass appliance is installed in a dwelling a carbon monoxide alarms must be fitted in (A) same room as the appliance and, (B) either inside each bedroom or within 5 meters of the bedroom door measured along the path of the corridor. Ref: building regulations doc J. Further guidance on the installation of the carbon monoxide alarm is available in IS EN 50291-1:2010/A1:2012 and from the alarm manufacturer's instructions.

**Provision of an alarm must not be considered a substitute for either installing the appliance correctly or ensuring regular servicing and maintenance of the appliance and chimney system.**

Your installer should have fitted CO alarms in the same room as the appliance and, either inside each bedroom or within 5 meters of the bedroom door measured along the path of the corridor. Ref: building regulations doc J. If the alarm sounds unexpectedly, follow the instructions given under "Warning Note" below.

### **WARNING NOTE – FUME EMISSION**

Properly installed, operated and maintained this appliance will not emit fumes into the dwelling. Occasional fumes from de-ashing and refuelling may occur. However, persistent fume emission is potentially dangerous and must not be tolerated.

If fume emission does persist, then the following immediate action should be taken: -

1. Open doors and windows to ventilate room and all people then to leave the premises
2. Let the fire out
3. Check for flue or chimney blockage and clean if required
4. Do not attempt to re-light the fire until the cause of the fume emission has been identified and corrected. If necessary seek expert advice.

The most common cause of fume emission is flueway or chimney blockage. For your own safety these must be kept clean at all times.

### **IN THE EVENT OF A CHIMNEY FIRE**

- Raise the alarm to let others in the house know.
- Call the Fire Brigade
- Reduce the appliance-burning rate by closing all air controls.
- Move furniture and rugs away from the fireplace and remove any nearby ornaments.
- Place a fireguard or spark guard in front of the stove.
- Feel the chimneybreast for sign of excessive heat.

If the wall is becoming hot, move the furniture away. Ensure that the Fire Brigade can gain access to your roof space in order to check this area for signs of fire spread.

## **8 Frequently Asked Questions**

**1 Do stoves require a chimney?** All of our multi fuel and wood burning stoves require a suitable chimney or professionally installed flue system.

**2 How do I clean the chimney?** You will require a chimney sweep to clean the chimney. It is essential to provide a dedicated chimney cleaning access door when installing the flue of the stove in some situations. In other situations the chimney can be swept through the firebox.

**3 Who should install my stove?** Mendip Stoves want you to enjoy the maximum performance from your appliance. To ensure this, it is essential that they are installed correctly. We strongly recommend that your stove is installed by a suitably qualified installer e.g. HETAS.

**4 How do I regulate the heat output?** Each stove has various air controls, which will allow you to easily regulate the heat output and refueling rate.

**5 What warranty do I get?** Mendip Stoves will replace, free of charge, any working part that fails (under normal operating conditions) within 12 months of purchase. Consumables such as glass, firebox lining boards or stove rope and adhesives are not guaranteed. **A call out charge will apply if our engineer attends any stove problem that is not related to product failure.**

**6 Where can I get spare parts?** Your local Mendip Stoves retailer will be pleased to supply spare parts and to provide any other information you require.

**7 Can the doors be left open while burning?** No for safety and heat efficiency the doors should remain closed.

**8 Why is the stove smoking when lit?** A flue with back draught problems is almost certainly the cause of a smoking stove. Also check adequate ventilation is present. A qualified fitter should complete both a smoke pressure and flow test prior to fitting the stove to ascertain the integrity of the flue.

**9 Why should I "Run in" my stove?** To begin, light a series of small fires over a period of a few days to allow the paint finish to cure. The stove is finished with a highly heat resistant paint. The finish can be renovated with stove paint available from your local stove retailer. If the stove is not "run in" correctly, this may cause the paint to discolour and flake.

**10 What is Over Firing?** Your stove should never be used in a manner to cause over firing. Over firing can be caused by over loading the stove with fuel, and with primary controls open. If any part of stove glows "red" your stove is over firing and your draught control should be adjusted to restrict airflow to stove. Over firing can cause permanent damage to the appliance, which is not covered by warranty.

## 9. SPARE PARTS LISTS & CODES

### Dinder 40 v3

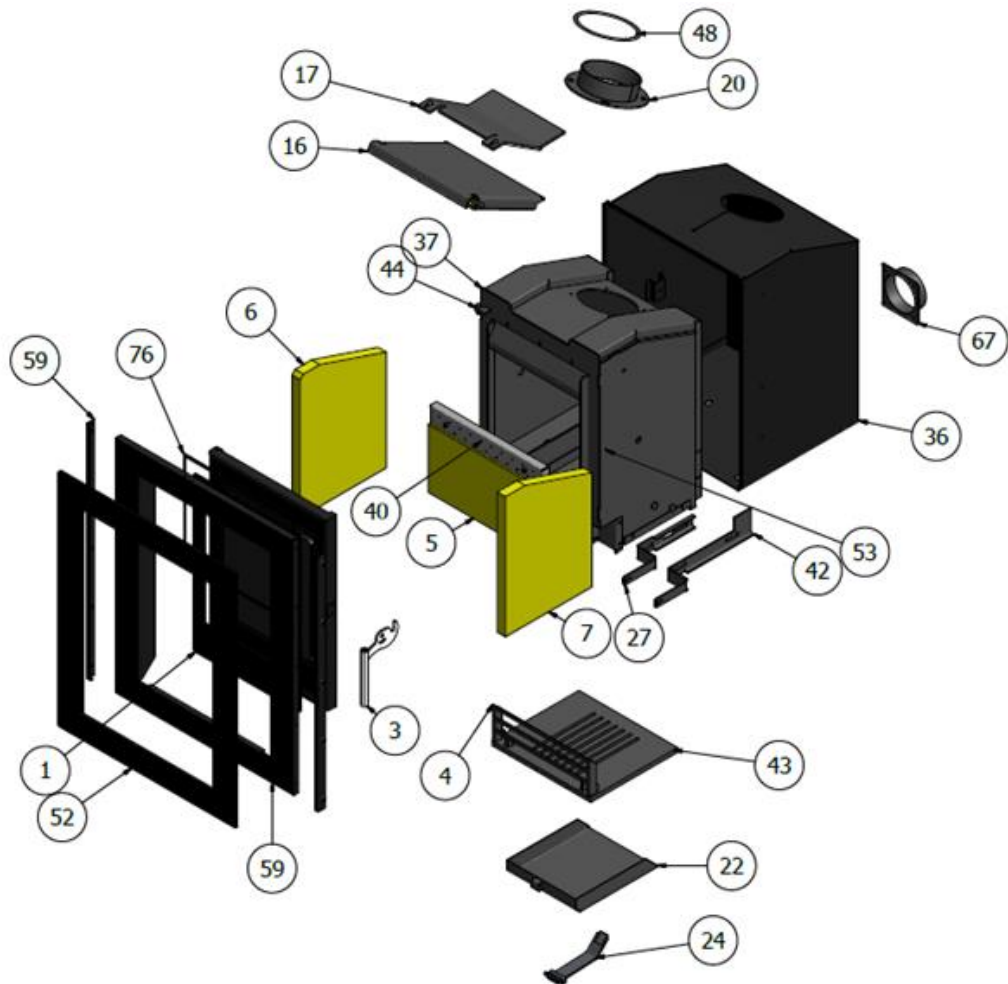

	Component	DINDER 40 V3		Component	DINDER 40 V3
1	Door Glass	Y1EOSC06D01A	36	Outer skin for Insert/Cassette	Y1HDC06D43C
2	Glass Brackets and Screws	Y1EOSC06D02A	37	Inner Skin for Insert/Cassette	Y1VTC06D44C
3	Door Handle assembly	Y1HDC03B	40	Tertiary Air box	Y1HDC06D47
4	Log Retainer	Y1HDC06D04A	42	Secondary Air Handle	Y1HDC06D49B
5	Back Plate/fireboard	Y1HDC06D05B	43	Static Grate	Y1VTL05D50A
6	Side Plate Left/fireboard	Y1HDCD06B	44	Door Hinge/Pin	Y1HDCD51C
7	Side Plate Right/fireboard	Y1HDCD07B	48	Rope Flat 2mm x 8mm (full roll)	Y1HD56A
16	Baffle Plate	Y1HDC06D19B	52	Glass for four sided front trim	Y1VTC06D60A
17	Baffle Plate Upper	Y1HDC06D20B	53	Door Latch roller	Y1VTCD61A
20	Collar	Y1HDC27E	59	Four sided trim for cassette – metal only	Y1VTC06D67B
22	Ashpan	Y1HDCD28B	67	External Air Collar	Y1HDC06D75A
24	Stove Tool	Y1VTC06D24B	75	10mm Rope	Y1HD83A
26	Door	Y1EOSC06D32A	76	6mm Rope	Y1HD84A
27	Primary Air Control	Y1HDC06D33C			

### **Guidance Note on Burning Solid Fuels / (Briquette Smokeless Fuel) and glass cleaning**

Please be aware that some smokeless fuels (Solid fuel / Briquettes) may cause the inner surface of the ceramic glass to turn cloudy or crystallise. This is caused by a reaction of some fuels during combustion process due to excess sulphur in the fuels. Unfortunately the glass manufacturers will not warrant their products from this phenomenon. Regrettably this cannot be controlled or prevented by the stove manufacture and therefore we cannot offer any warranty. There are no known safety issues, the only effect will be a visual one.

Solid fuel requires air from underneath the grate which in turn reduces the effects of the secondary airwash, you will notice a dark grey haze on the back of the ceramic glass. It is important to clean this off the glass when the stove is cold using a stove glass cleaner. Repeated firing of the stove without cleaning the glass daily, when burning solid fuel greatly increases the chances of glass turning cloudy / crystallising.

To minimise this condition we strongly recommend burning well-seasoned or kiln dried wood logs using only the airwash controls only, (Primary air controls closed).

#### **Cleaning of the ceramic glass:**

Despite the advanced air wash system provided, the glass will still need cleaning from time to time depending on the fuel quality and burning rates used. Never clean glass when the stove is hot. Always use stove glass cleaner or ceramic hob cleaner, which is available from your stove retailer. Apply the cleaner to a cloth and then the glass, **NOTE** do not apply excessively. **PREVENT** any run off which could soak into the rope seals, soot contains acidic particles that can cause corrosive damage to the colour print on the glass.

# **GLASS IS NOT COVERED UNDER WARRANTY**